

SNOW & ICE EQUIPMENT

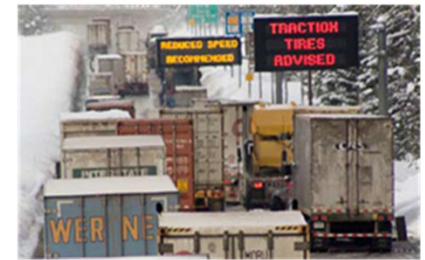

Greg Hansen, Fleet Administrator
James Morin, Maintenance Operations Manager
June 7th, 2016

Equipment Plays a Critical Role in Operating and Maintaining The Highway System



TEF Equipment

4,800 Vehicles & Construction Equipment



10,000 Pieces of Supporting Equipment

- 4,500 - Wireless Radio System Components
- 1,350 - Equipment Attachments (primarily snow and ice)
- 410 - Fuel System Components and Generators
- 40 - Reproduction and Photogrammetry Pieces

- 500 - Field Engineering Survey Equipment
- 1,700 - Materials Lab Testing Equipment
- 1,110 - Message Signs and Impact Attenuators
- 390 - Equipment and Lab Trailers

Washington State Department of Transportation

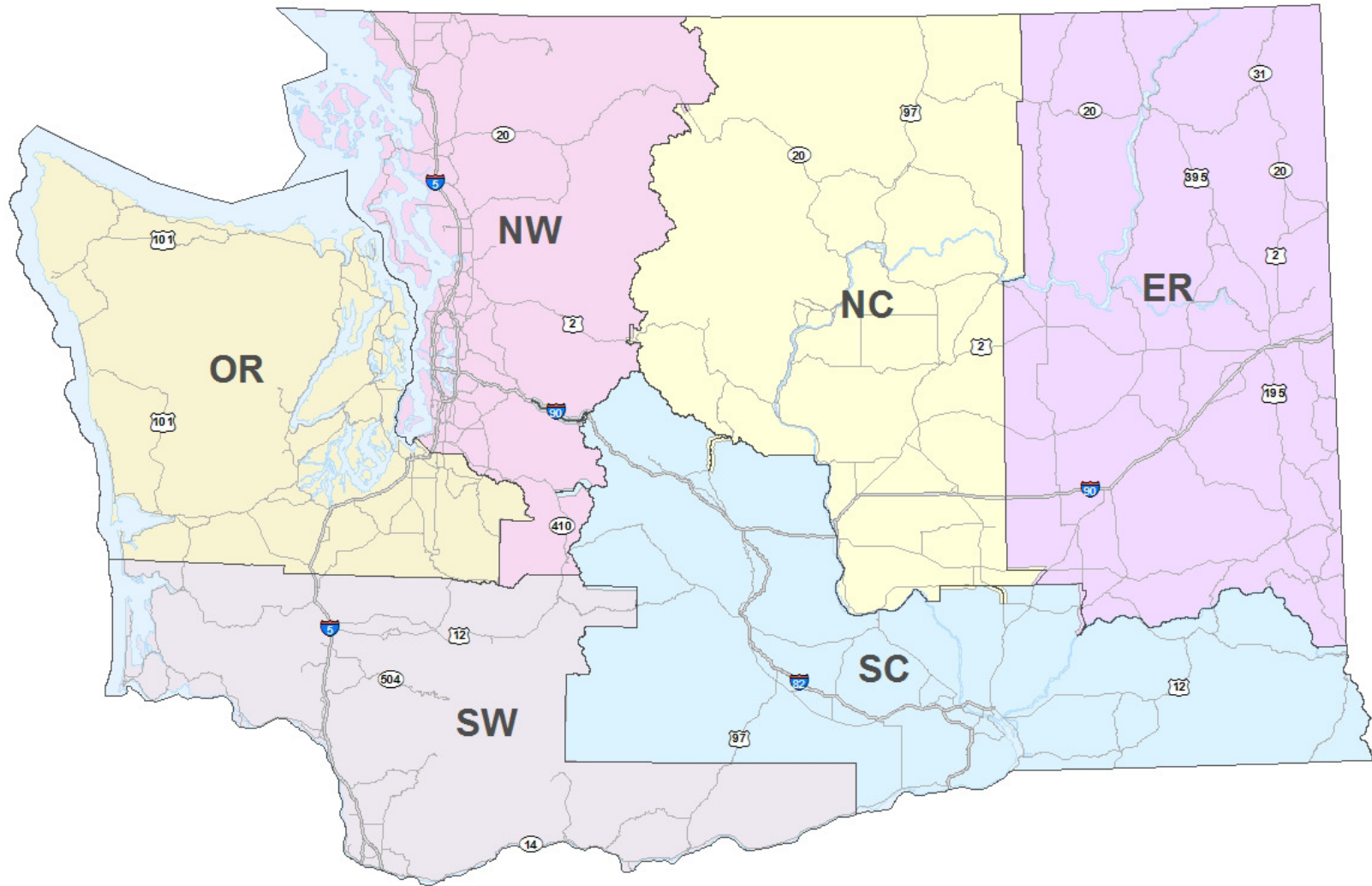

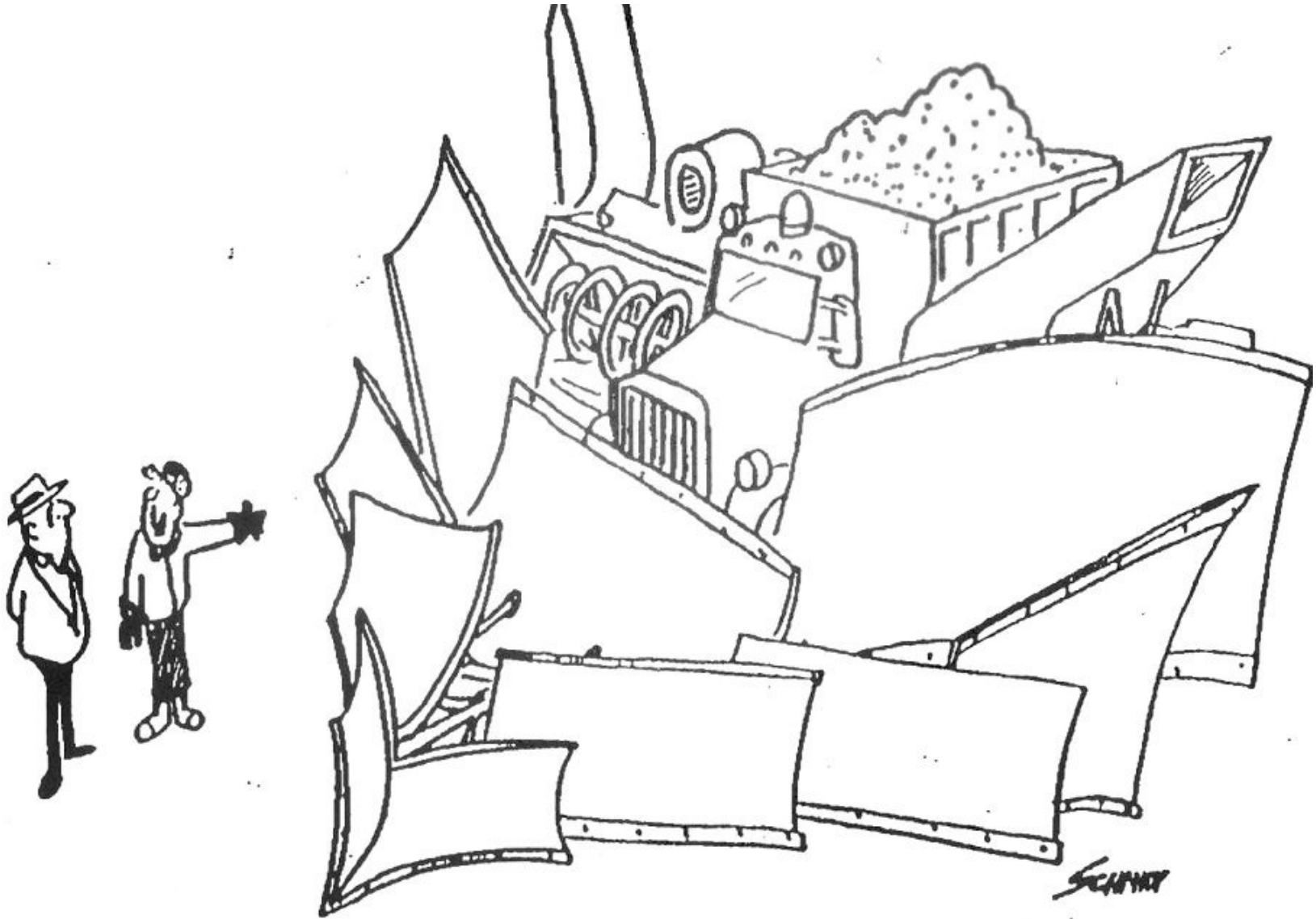

THIS BABY DOESN'T MISS A FLAKE OF SNOW...!

MODOT

10 Yard Tandem



Double Dump

10 Yard



5 yard



Side Dump



4x4



Henderson Spreader



Monroe Slip In



Schmidt



SS Fix Mounted Hopper



End Dump/Busby



In bed Sanders



Tailgate Prewet



Force America Controllers



What's new in WSDOT's Fleet

Bumble Bee Quick Response Trucks



Laser for Wing Plow Safety



Eaton Fuller Ultra Shift



Parallel Lift System



Parallel Lift Plate



Slotted Trip Expressway



Stucci Connector

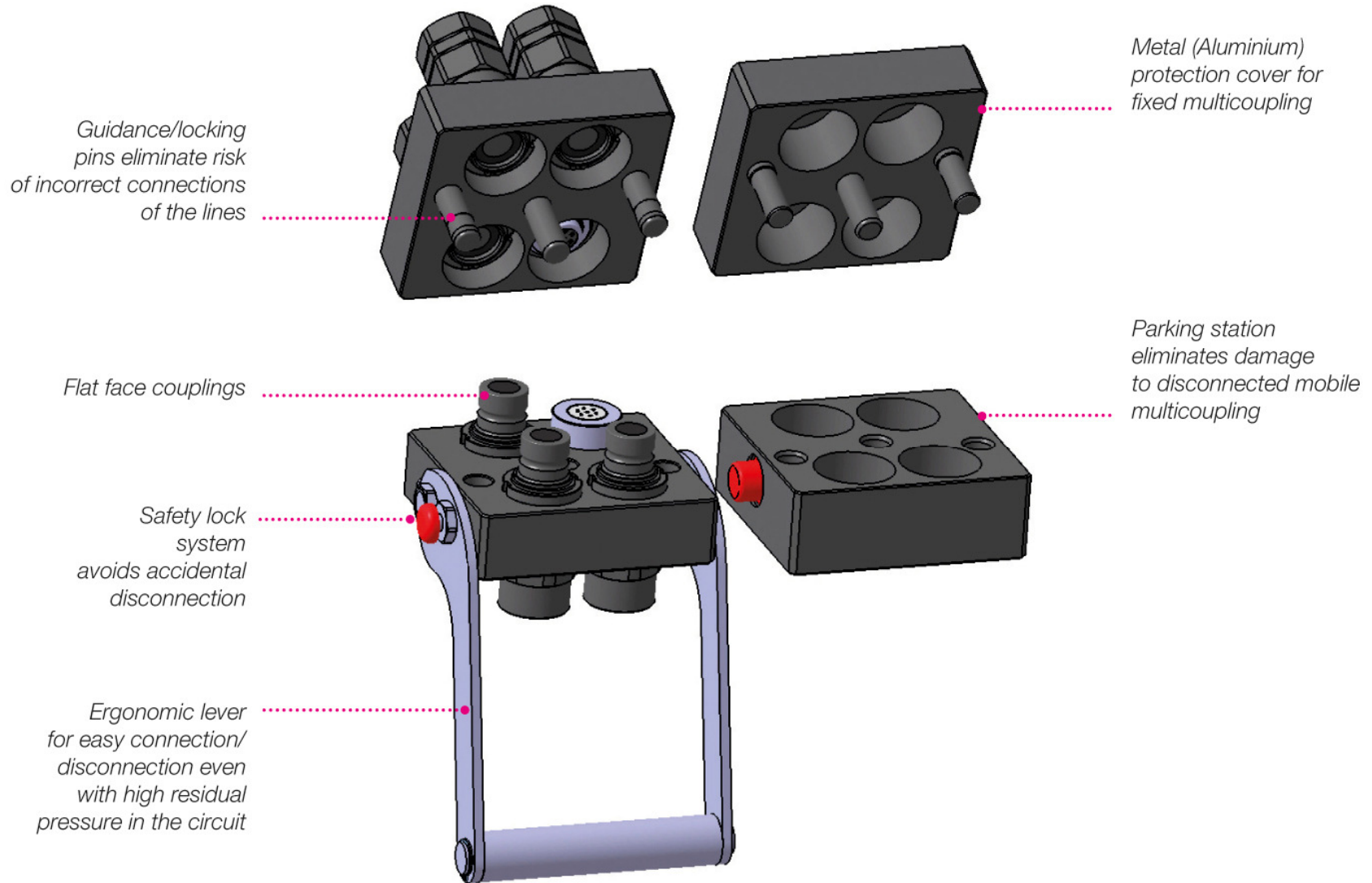

Stucci Connector

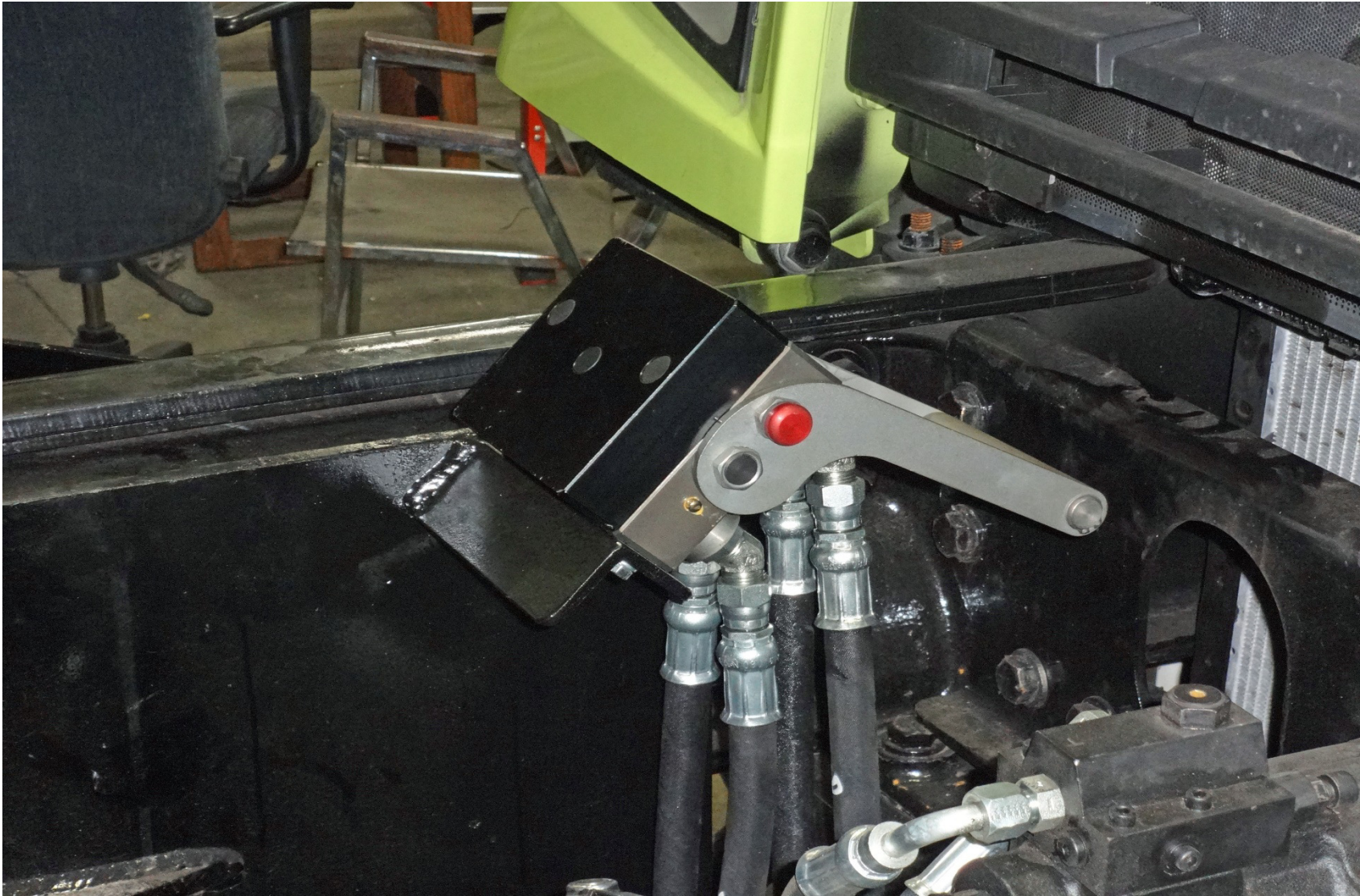

Postless Wing Plow

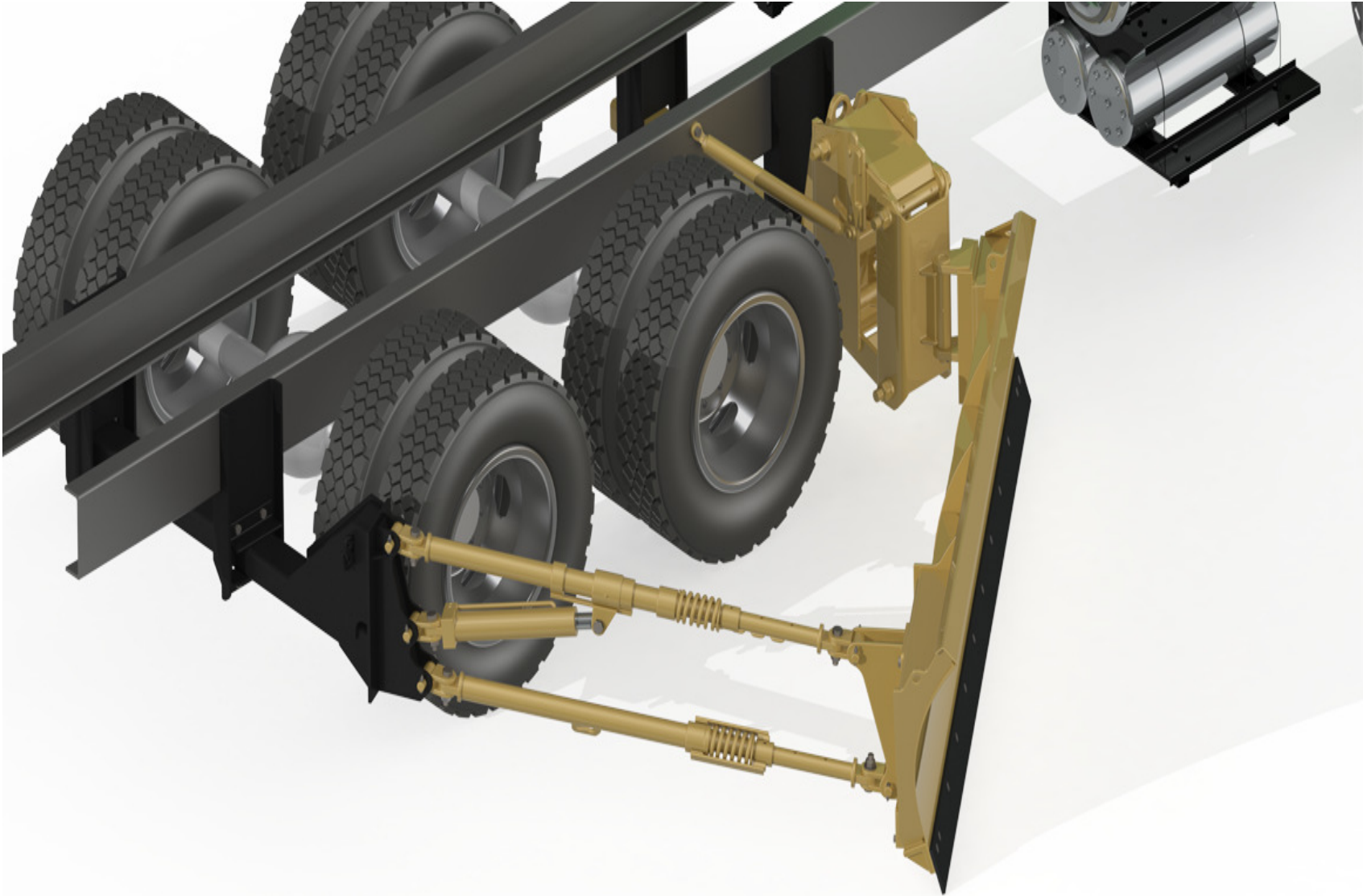

Postless Wing Plow



Hook Lift System



Hook Lift System

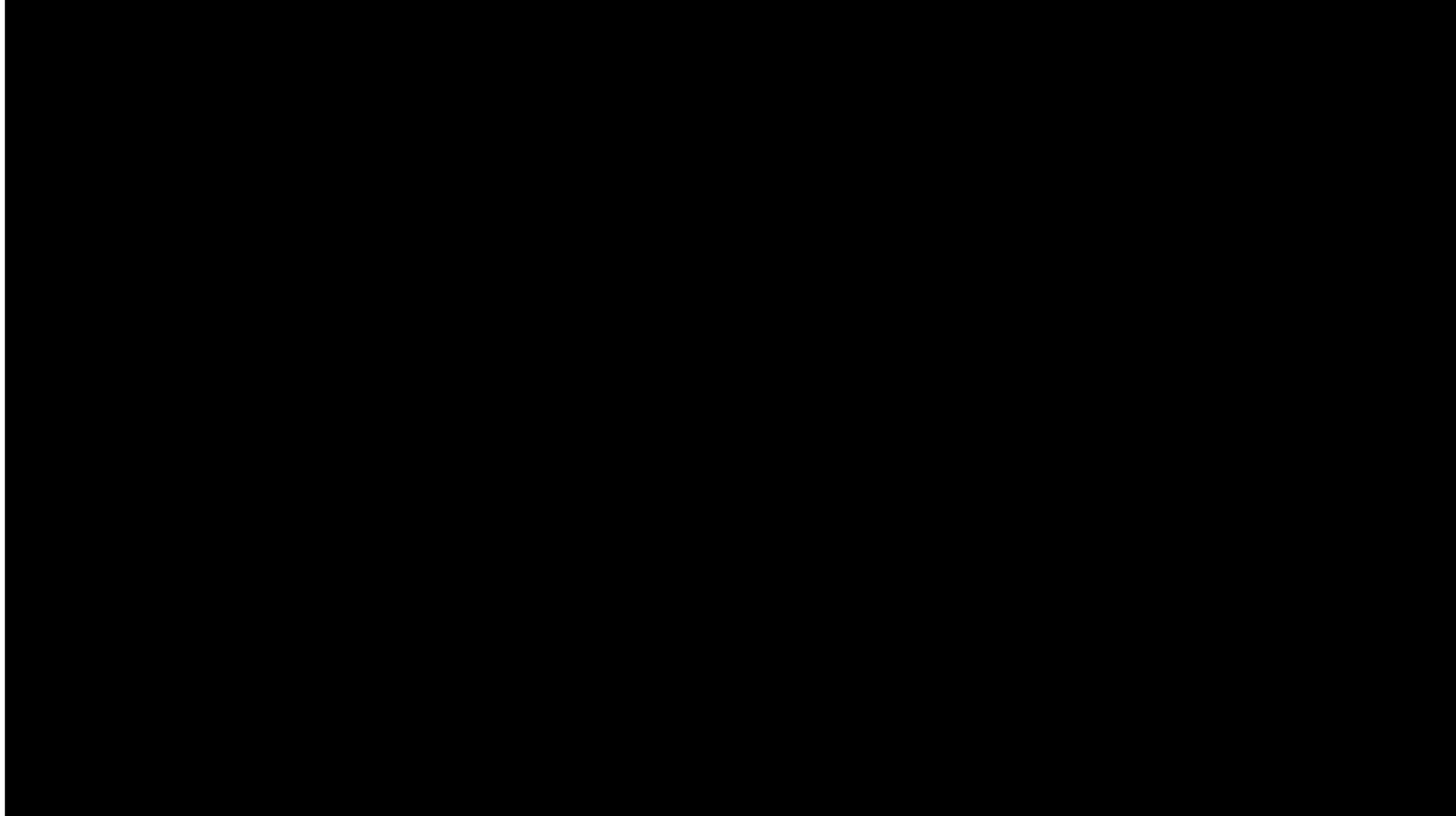

Hook Lift System



Single Function Trucks



One Truck Multiple Functions



Air Disc Brakes



- Air Disc Brakes on Europe Roads 20 million
- Air Disc Brakes on US Roads 400 thousand
- Stopping Distance over drum 25%
- Changing air disc brake pads takes less than half the time it typically takes to change drum linings

FMVSS-121 Requirements

Stopping Distances – Air Disc Required?



Product enhancements have reduced the gap between air drum and air disc brake performance

Grip Idle Management System

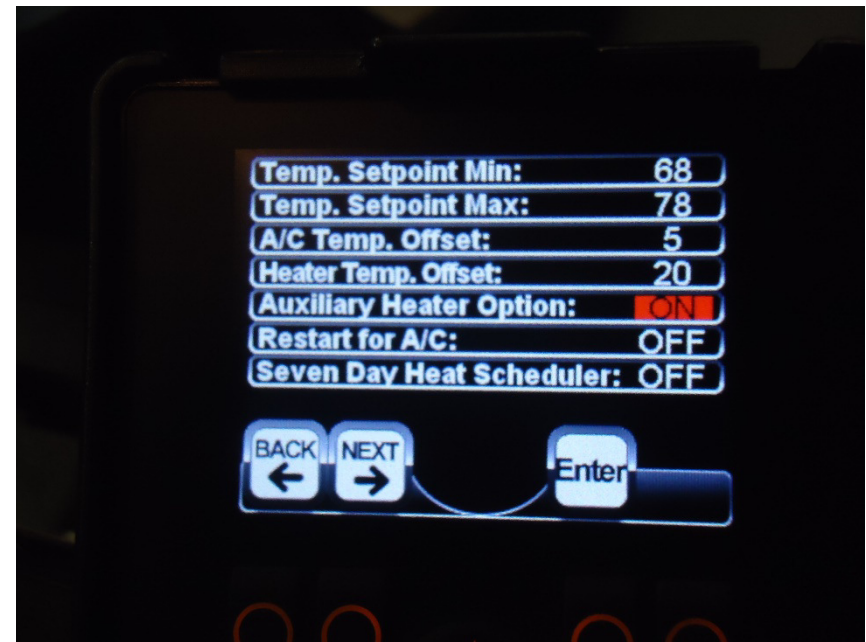

2015 Dump Truck Corrosion Repairs

\$327,000

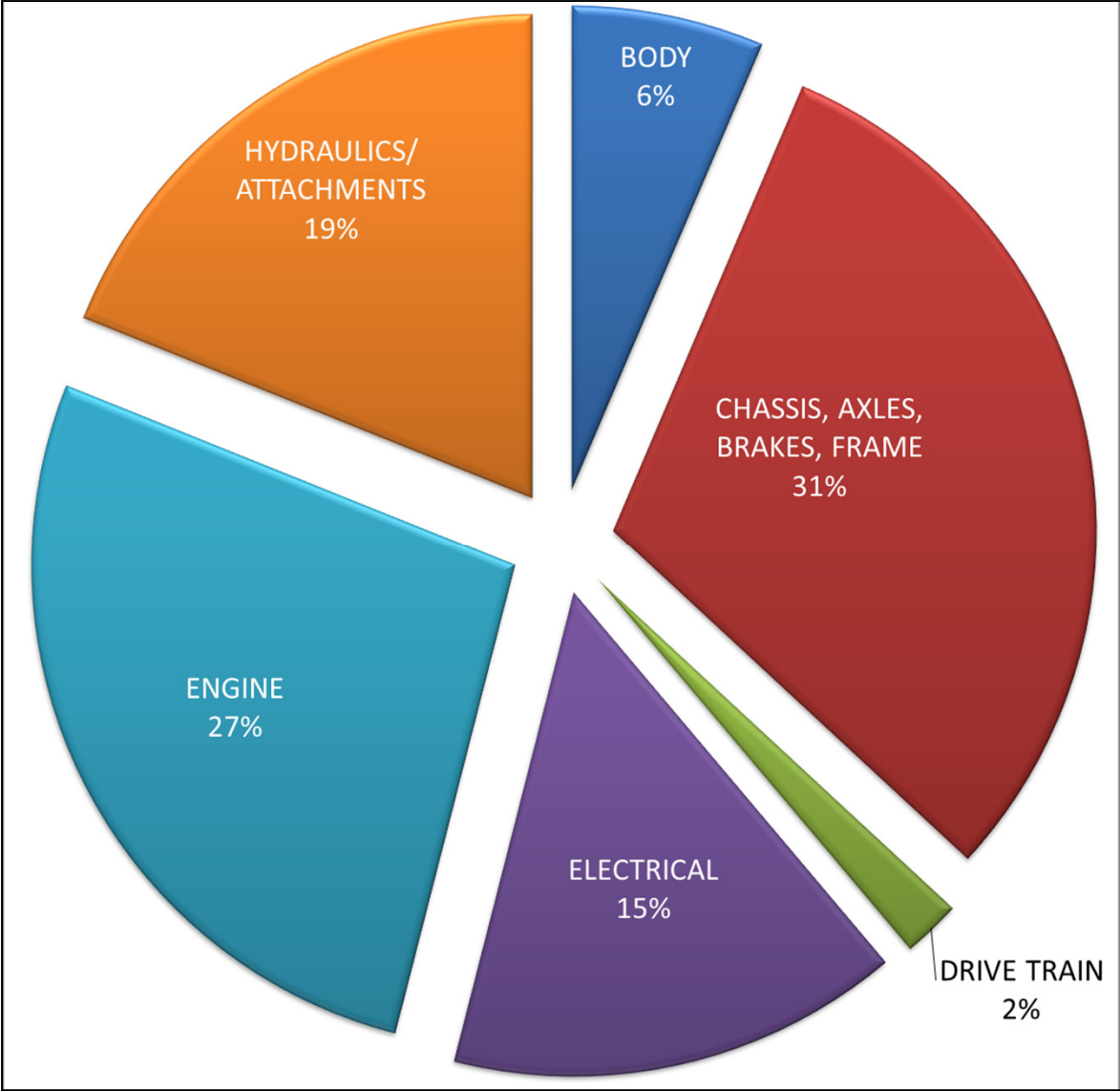

Clear Roads

Manual of
Best Practices
for the Prevention of Corrosion on Vehicles and
Equipment used by Transportation Agencies for
Snow and Ice Control

April 2015



Prepared by:
Mehdi Honarvar Nazari
Dave Bergner
Xianming Shi

Published by:
Minnesota Department of Transportation
Research Services & Library
395 John Ireland Boulevard, MS 330
St. Paul, Minnesota 55155-1899

Western Transportation Institute
Montana State University

CLEAR ROADS
research for winter highway maintenance

Wash Your Equipment





Truck Comparisons

	cost to purchase with hopper or prewet	annual maintenance cost to include hopper or prewet	Availability	Days in Shop for repairs	Range/miles @ 200lbs per lane mile sand 2760 lb per yard	Legal Solid Capacity (Cy)
0604 38K GVWR, CONTRACTOR BODY, AUTO TRANS	\$202,800	\$4,500	87%	48	69	5
0606 38K GVWR, CONTRACTOR BODY	\$193,800	\$3,900	87%	48	69	5
0605 38K GVWR, DOUBLE DUMP BODY, AUTO TRANS	\$215,300	\$4,900	89%	40	55	4
0607 38K GVWR, DOUBLE DUMP	\$205,300	\$5,000	88%	44	55	4
0608 38K GVWR, W/ SIDE TIP	\$218,800	\$6,000	87%	48	62	4 1/2
0613 58K GVWR, CONTRACTOR BODY	\$241,000	\$7,400	84%	59	138	10
0614 58K GVWR, DOUBLE DUMP BODY	\$251,200	\$8,000	82%	66	124	9
0616 58K GVWR, W/ SIDE TIP	\$267,100	\$6,500	81%	70	117	8 1/2

Tow Plow Pilot





TowPlow Research & Experience:

- **Missouri Department of Transportation:** 83 Tow Plows
- **Nebraska Department of Transportation:** 21 Tow Plows
- **Minnesota Department of Transportation:** 10 Tow Plows
 - \$38k per year savings for each TowPlow compared to Standard truck, based on lane mile cost
- **Ohio Department of Transportation:** 3 Tow Plows
 - By University of Akron
 - \$22k savings per year per truck
 - http://www.dot.state.oh.us/Divisions/Planning/SPR/Research/reportsandplans/Reports/2015/Maintenance/134704_FR.pdf



Automatic Vehicle Location (AVL)

- 350 of 500 truck fleet
- Tort Liability
- Rate vs Quantity (Daily Summaries)
- Versatility and Consistency



Data / Communication Flow

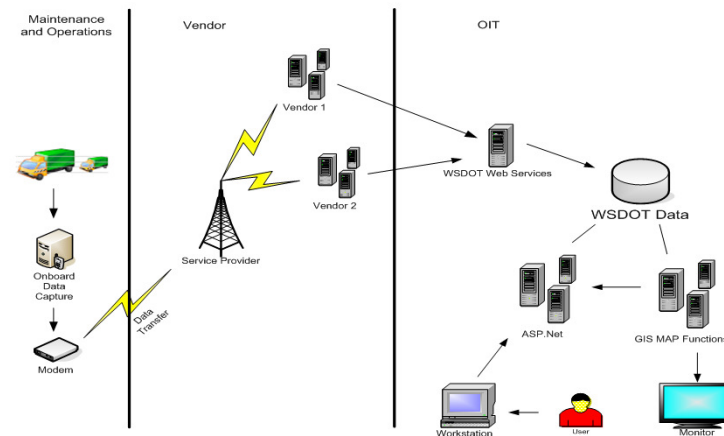

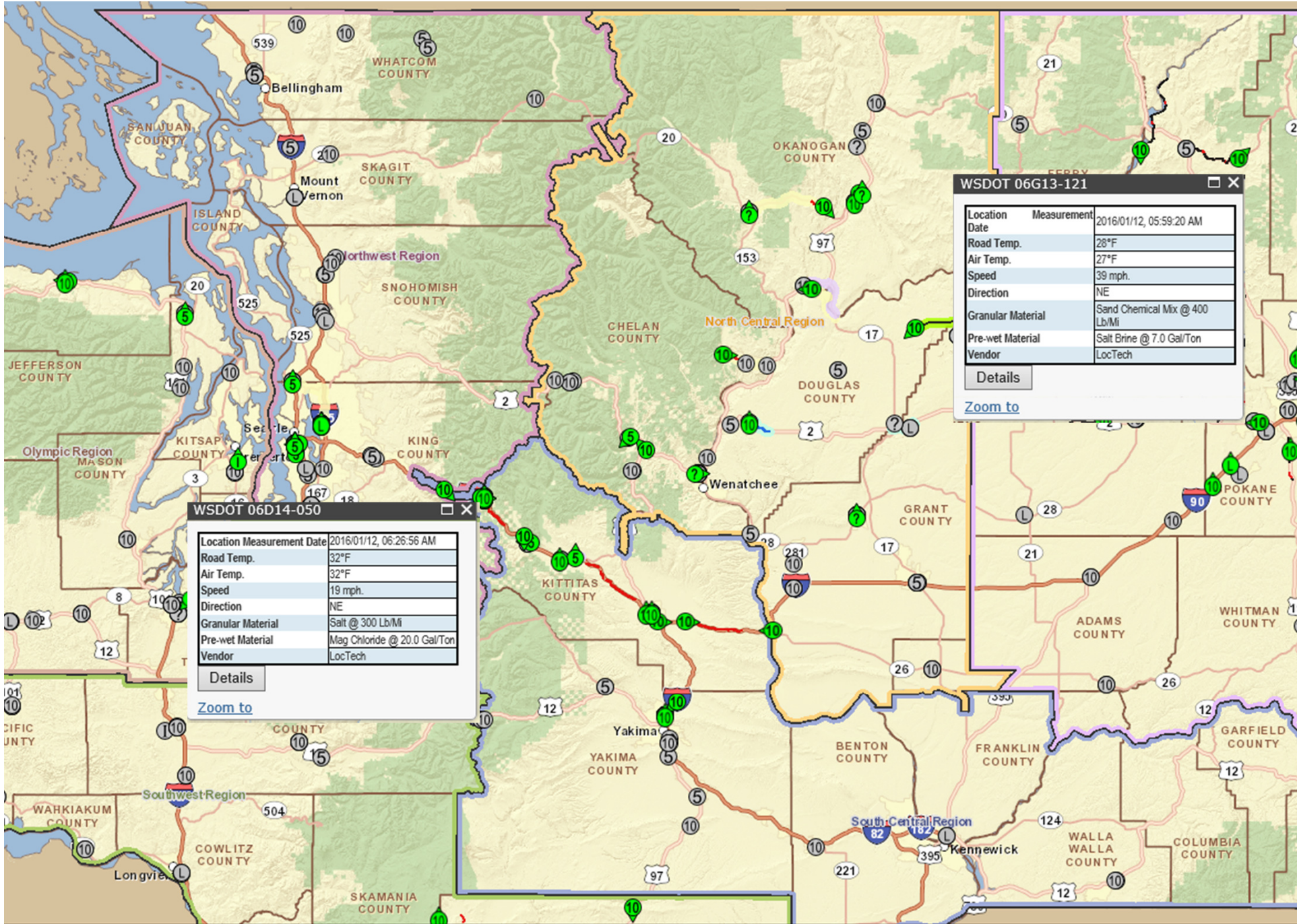

WSDOT 06G13-121

Location	Measurement	2016/01/12, 05:59:20 AM
Road Temp.		28°F
Air Temp.		27°F
Speed		39 mph.
Direction		NE
Granular Material		Sand Chemical Mix @ 400 Lb/Mi
Pre-wet Material		Salt Brine @ 7.0 Gal/Ton
Vendor		LocTech

Details

[Zoom to](#)

WSDOT 06D14-050

Location	Measurement	2016/01/12, 06:26:56 AM
Road Temp.		32°F
Air Temp.		32°F
Speed		19 mph.
Direction		NE
Granular Material		Salt @ 300 Lb/Mi
Pre-wet Material		Mag Chloride @ 20.0 Gal/Ton
Vendor		LocTech

Details

[Zoom to](#)

How to pull a car with a plow

